



STRATUS MONO

THE STRATUS MONO IS A SLEEK, GLASS CEILING HOOD AVAILABLE IN BLACK OR WHITE. THE PRECISION MOVEMENT OF THE DESCENDING EXTRACTION PANEL INCREASES THE CATCHMENT AREA AND ENABLES DIRECT AIR FLOW INTO THE HOOD. THIS IMPROVES PERFORMANCE AND EFFECTIVENESS BY 7% WHEN COMPARED TO CONVENTIONAL CEILING HOODS.

WIDTH	900MM OR 1200MM
DEPTH	430MM
HEIGHT	236MM
FINISH	WHITE GLASS OR BLACK GLASS
CONTROLS	4 SPEED REMOTE CONTROL
LIGHTING	4X 3.4W NATURAL WHITE(4000K) DIMMABLE LED
FILTERS	CONCEALED ALUMINIUM MESH, SUITABLE FOR DISHWASHERS
DUCT POSITION	LEFT, RIGHT, FRONT, REAR OR TOP
MOTOR OPTIONS	INTERNAL, OR RECIRCULATING
ENERGY RATING (INTERNAL MOTOR)	B
ENERGY RATING (REMOTE MOTOR)	N/A
AIRFLOW RATING (INTERNAL MOTOR)	800 CMPH
MAXIMUM DB LEVEL (SPEED 4 - BOOST)	75DB (INTERNAL MOTOR)
POWER SUPPLY REQUIREMENT	3 AMP (INTERNAL MOTOR)
DUCT SIZE	220MM X 90MM RECTANGULAR
CUTOUT SIZE	868MM/1018MM X 405MM



BLACK GLASS (OPEN)



WHITE GLASS (CLOSED)

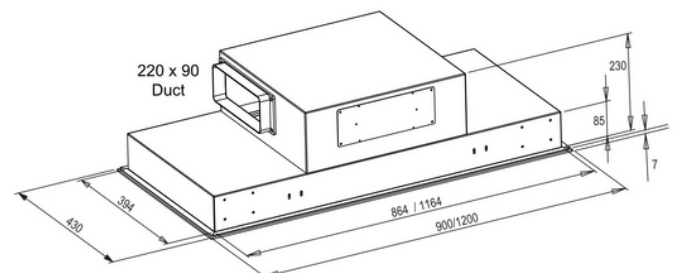



WESTIN

STRATUS MONO

Ceiling Built-in Unit

Installation, Operation and Maintenance

CONTENTS

INTRODUCTION	2
IMPORTANT INFORMATION	2
EXTRACTION PERFORMANCE	3
INSTALLATION	4
SPECIFICATIONS	6
OPERATING INSTRUCTIONS	7
MAINTENANCE	8
GENERAL ARRANGEMENT DRAWINGS & ILLUSTRATIONS	9

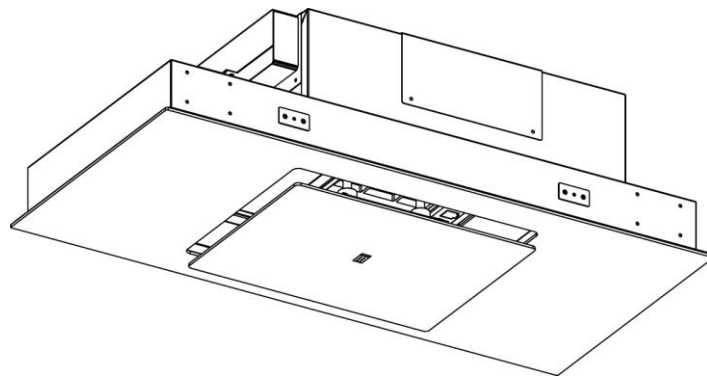

UNPACKING

Remove all items from the packaging. Retain the packaging. If items are missing or damaged, please contact Westin for assistance.





Installation, Operating & Maintenance Instructions

1. INTRODUCTION

During the cooking process, there will be heat, vapours and fumes produced. Your *Westin Ceiling Extractor* has been designed to complement your kitchen both in looks and performance, in order to create a good environment for creative cooking.

2. IMPORTANT INFORMATION

The exhaust air **must not** be discharged into a flue which is used for exhausting fumes from non-electric appliances such as oil or gas-fired central heating boilers or gas-fired water heaters, etc.

Requirements of the relevant authorities concerning the discharge of exhaust air must be complied with.

Pay particular attention to fire risk when frying. To minimise the risk of fire, all instructions relating to cleaning the grease filter and removing grease deposits must be adhered to.

Do not flambé under the extractor.

WARNING.

Proper care must be taken to ensure that the negative pressures caused by high performance extraction systems do not adversely affect the safe operation of certain types of fuel-burning appliances (gas, oil or solid fuel), including those installed in the kitchen and also those installed in other parts of the house.

Where such fuel-burning appliances are installed, adequate ventilation **MUST** be provided in the room of installation, located and sized such that the negative pressure in the room created by the extractor does not exceed 4Pa.

In case of doubt, do not operate the extractor and fuel-burning appliance(s) simultaneously and consult an appropriate (for the fuel type) expert for advice.

ELECTRICAL SAFETY.

This appliance requires an earth connection.

Ensure that the supply voltage corresponds to that marked on the rating label inside the extractor.

The extractor must be isolated from the electrical supply before carrying out any cleaning or maintenance operations.

The clearance between the hob burners and the bottom surface of the cooker hood (extractor) should be within the following range, unless a greater distance is specified by the cooking appliance manufacturer:

Hob to underside of the cooker hood clearance distances:

- 650mm Minimum above electric hobs.
- 760mm Minimum above all gas hobs and gas or electric wok burners, griddles, fryers, open grills / barbecues.

The minimum distance between the hob and the bottom of the cooker hood is essential for safety reasons and to prevent overheating of the extractor and its components.

Please also note that a 90° bend in flexible ducting will require 215mm minimum headroom to give a smooth radius with no kinking.

You are advised to install measures designed to reduce the incidence of cold draughts entering the property via any ductwork.

For extractors with internal or inline motors, this should, at the very least, consist of an external duct termination with integrated

non-return flaps (e.g. gravity shutter wall grille/louvre) and/or an inline backdraught shutter.

For wall-mounted motors, an inline backdraught shutter is recommended.

3. EXTRACTION PERFORMANCE

This type of extractor is designed to fit into the ceiling void, with only the glass underside and the edge of the outer steel flange visible when installed.

Because fumes spread out as they rise, a unit larger than the hob area is desirable (although not always possible). The drop-down central extraction system is designed to minimise fume escape. Warm cooking fumes that do escape tend, initially, to

accumulate in the highest part of the room, so situating the unit at the highest point is of benefit. It will perform best when it is situated directly over the hob.

The primary influence on the overall performance of the extractor is the design of the ducting which takes the exhaust air from the extractor to the outside. The duct route should be a prime consideration during the initial stages of the kitchen design (Westin do not recommend recirculating air back into the kitchen).

Please note the following:

- Easy access to the duct route during installation is important. Lack of access may require the “blind” fitting of flexible ducting (with increased risk of unseen kinks and impaired efficiency).
- The extractor is provided with a spigot suitable for connecting 220 x 90mm rectangular ducting. (A duct connector that converts the rectangular ducting to 150mm diameter ducting is available upon request).
- Note: to maintain efficient extraction, the cross-sectional area of the ducting must be 150mm diameter or greater.
- The most efficient configuration is to duct straight through an outside wall, so try to position the cooker against an outside wall when designing your kitchen.
- Your extractor can be set to vent to the rear, front, left or right. Use the exhaust position which gives the shortest achievable duct route and least number of bends. Joist positions will often determine what is achievable.
- Rigid 220 x 90 channel system or an equivalent 150mm round ducting system (available from *Westin*) will perform best. The appliance is supplied with a length of 600mm long flexible ducting that should aid initial installation and should be pulled taut to prevent significant losses in extraction efficiency.
- For maximum efficiency, ducting should be kept as short as possible and as straight as possible with a constant cross-sectional area equivalent to 150mm diameter ducting. Bends in the duct will also degrade performance so the number of bends in a duct run should be kept to a minimum and be gradual and smooth to prevent turbulence. Avoid kinks in flexible ducting; pull flexible ducting taut over straight runs to ensure that the internal surface is as smooth as possible.

4. INSTALLATION

The extractor is designed for installation within a cut-out in the underside of the kitchen ceiling. Alternatively, it may be installed within a lowered area of ceiling or a soffit panel within your furniture – remember though that it is desirable to install directly into the ceiling (see section 3).

Dimensioned drawings and illustrations to help with your installation can be found on page 8 onwards.



Opening the Glass Door

To open the door, separate the glass panel from the base plate by first locating the arrows marked 'OPEN HERE'. Use your fingers to pull the glass panel away from base plate. The glass panel is hinged to the rear of the unit and is supported by two gas filled struts. These struts assist in raising the door once opened. NOTE: The struts make it much more difficult to open the door should the door be opened when the product is on its back (i.e. pre-installation).

CAUTION – To prevent damage to the unit, only open the glass door at the positions shown by the removable arrow stickers (see illustration).

CAUTION – Beware of finger entrapment between surfaces.

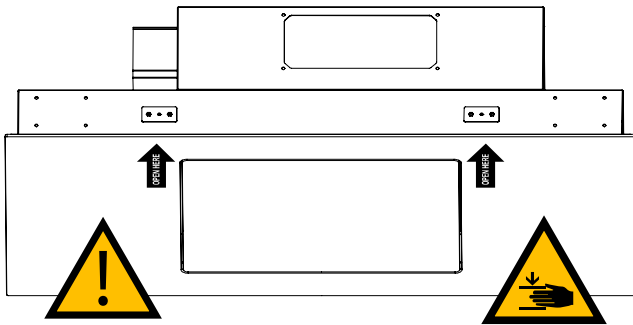

Installation aid – Fitting the Strut Locking arm.

Fit the locking arm (x1) to the strut via the Velcro tabs to lock the door open during the installation process if required.

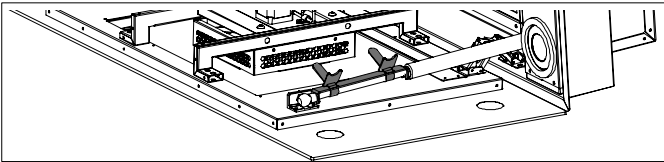

Revealing the fixing holes.

The extractor fixing holes are hidden behind the four LED down lights. These can be removed by pulling the light down by the bezel to reveal the fixing hole. (see below).

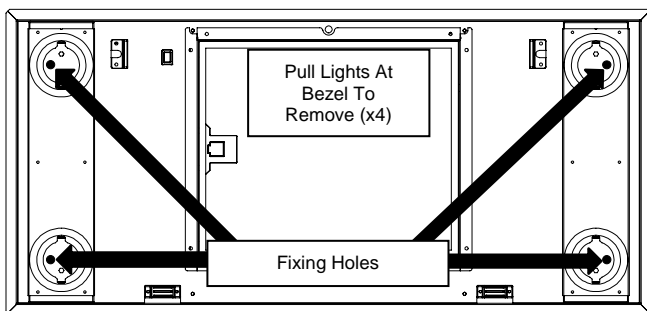

Should extra fixing holes be required, remove the 6 machine screws from each light pod plate to reveal an additional (central) fixing hole on each side.

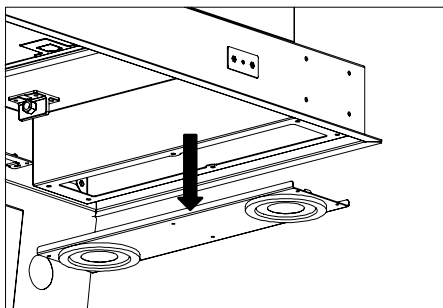

If your extractor is a recirculating model (optional extra and not the standard configuration) then adequate provision must be made for exhausted air to return into the kitchen - e.g. ducted out to a ceiling vent sited to minimise uncomfortable draughts. Failure to do so may cause the unit to malfunction. (This will invalidate your warranty).

Setting the Duct Spigot Position.

Your extractor ducting spigot can be set to vent to the Left (factory default), Front or Rear.

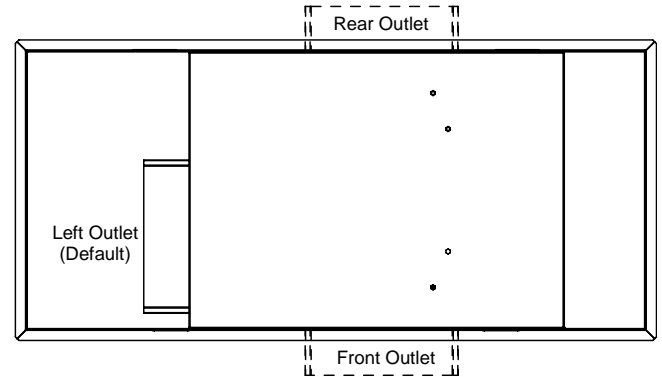

The front of the unit, when installed, is the side with the magnetic catches.

Note: If you wish to vent upwards, then you may find your installation easier if you use a left outlet position and put a bend upwards in your ducting.

If you wish to vent out using the front or rear outlet, simply remove the 6 fixing screws in the blanking plate and the spigot plate itself and interchange accordingly.

If you wish to duct out to the right, then the entire product will need to be rotated within the cut-out.

Prepare the Opening.

Prepare an opening in the ceiling into which the unit will be fitted (see table below). Reinforce the opening as necessary and make suitable provisions for the screws that will hold the unit in place.

Unit Size (mm) (Width x Depth)	Cut-out Size (mm) (Width x Depth)
900 x 430	868 x 405
1200 x 430	1018 x 405

Note: To avoid the need to box down from the ceiling, consider the joist direction, ceiling thickness (and possibly lowering the ceiling slightly). Boxing down can usually be avoided with minimal alterations to the ceiling arrangement.



Stratus MONO Ceiling Built-in Unit

Installation, Operating & Maintenance Instructions

Accessing the filter.

The filter is positioned in the centre of the base plate panel, behind the glass door. The door is held shut with two magnetic catches.

Open the glass door by grasping the edge of the door close to the vent inlet panel (see OPEN HERE arrows on illustration above). Pull the glass door to release the panel from the magnets. Remove the filter (detailed instructions are provided in SECTION 5).

Closing the Door.

The door should be closed by pushing the glass panel up until the door re-engages with the magnets. Care should be taken to avoid finger entrapment. Care should also be taken not to push the door via the central panel. The door hinge may sag during the door open / close procedure, if the lights look like they have slightly misaligned from the light apertures in the door panel, the door panel can be re-aligned by pushing the panel in the direction required to re-align.

Ducting

Install ducting taking note of the advice given in section 2 & 3.

We recommend using semi-rigid round ducting for this extractor. The initial connection to the extractor spigot must be in semi-rigid (or flexible duct) to allow the entire unit (or top box if fitting separately) to be pushed into position with the duct connected.

Run the ducting such that there is enough to easily reach just beyond the centre point of the extractor, thus allowing for a short length to be pulled through the opening for later connection to the top box spigot. Try to avoid tight bends immediately adjacent to where the top box will be as this will make pushing the unit/top box into position more difficult.

When terminating ducting on an outside wall, a suitable weather louvre should be fitted. Various ducting components and complete kits are available from *Westin* to suit most installations.

If you plan to use expanding foam, make sure that any soft flexible ducting is supported internally to prevent it crushing, or use semi-rigid/rigid ducting where foam is used.

For roof or chimney duct terminations, please contact *Westin*, or seek alternative specialist advice.

If you are fitting a wall-mounted external motor with semi-rigid or flexible ducting, then you must leave a short length (approx. 200mm) of expanded (stretched out) ducting proud of the wall (to facilitate connection to the motor spigot) before pushing both into position flush with the wall.

Standard external motors come with a cable assembly and fitted plugs that must pass through the wall and run back to the extractor – usually this passes alongside the ducting so it is recommended to oversize your cut-out by at least 25mm to allow for this (and for the easy installation of the duct).

The extractor is a stationary appliance supplied with an electrical supply flex and moulded 3 pin UK plug (3A) for connection to the electrical supply.

The appliance must be fed from a 230Vac single phase electrical supply. You may wish to terminate the electrical supply using a standard mains electrical socket positioned close to the extractors intended location.

Alternatively, you may terminate the electrical supply from a switched-fused spur. The spur should be located adjacent to the hood/cooker so that the supply can be disconnected from the hood using the switch. The means of disconnection from the supply must have a minimum contact separation of 3mm in all poles. A competent Part P registered electrical technician must perform the electrical installation.

The mains supply is connected as follows:

INCOMING SUPPLY CORD CONNECTIONS	
Core	Core Colour
Live	Brown
Neutral	Blue
Protective Earth	Green/Yellow

Make sure the switched - fused spur supplying the extractor is in the 'off' position before connecting the appliance to the electrical supply.

Fixing the Extractor in Position

Please note the following prior to commencing fixing the extractor in position:

You will need at least 2 people to fit this extractor; to lift, hold and fix the unit in position:

A working platform or scaffold should be used so that the ceiling opening can be reached and the unit fixed without the use of ladders.

Screws for fixing the extractor into position are not provided. You must use suitable fixings capable of supporting 30kg per screw.

If you are screwing into timber, then you should use screws no smaller than 5mm (No 10) with a head diameter of 10mm or more and ensure that at least 35mm of thread is screwed into the timber and that the timber will not split when the screws are inserted.

The unit will need supporting close to the opening when attaching the ducting and making electrical connections – do not be tempted to install excessive ducting as this will impair performance.

As described earlier, a length of semi-rigid ducting protruding a short distance through the centre of the ceiling opening is sufficient for the final connection to the extractor spigot. This will allow the unit to be fixed into position with the duct connected and prevents excessive lengths of flexible ducting being pushed into the opening. This may lead to loss of efficiency. (see section 3).

KEEP FINGERS AWAY FROM ANY MOVING COMPONENTS & SURFACES. THE CENTRAL MOVING PANEL MUST NOT BE TOUCHED, MOVED MANUALLY OR INHIBITED DURING THE DOWNWARD OR UPWARD CYCLE.



You must consider and allow for the future removal of the extractor and any remote motor when planning and undertaking your installation should access for future servicing be required.

Electrical Installation

ELECTRICAL HAZARD. DISCONNECT ELECTRICAL SUPPLY BEFORE PROCEEDING FURTHER



- If you have not already done so, set the top box to duct out in the required direction, as described in SECTION 4 and reveal the corner fixing holes (concealed and recessed within the light cavity), as described in SECTION 4.

Stratus MONO Ceiling Built-in Unit

Installation, Operating & Maintenance Instructions



- Support the extractor just below the prepared cut-out so that the spigot and electrical connections are accessible.
- Make sure that the electrical supply to the electrical supply spur is isolated (switched off) and connect the electrical supply cord of the extractor to the spur.
- Attach the ducting to the spigot using suitable clamps or straps (available from Westin). We do not recommend using duct tape as the only means of fixing - this should only be used to improve the seal in the joint.
- Push the extractor up into the cut-out, taking care not to crush or introduce excessive bends/kinks in the ducting and making sure that no wires are trapped or damaged in the process.

Note: If the duct or any wires are trapped, then you must lower the extractor and make corrections to the cut-out area as necessary before fixing the appliance in position.

- Secure the extractor in place using suitable fixings (not supplied) through one fixing hole in each corner of the baseplate.
- Now test the function of the unit as described in the operating instructions (SECTION 6).

If the lights or motor do not function correctly, then isolate the electrical supply and check all the electrical connections before contacting Westin.

If you experience any further difficulties, please call Westin for advice.



Levelling the Glass Door

The extractor is supplied with the glass door pre-aligned with the base plate assembly (the main (steel) part of the extractor).

Should the door become misaligned during assembly, or if the door does not sit adequately level once installed, the door can be adjusted.

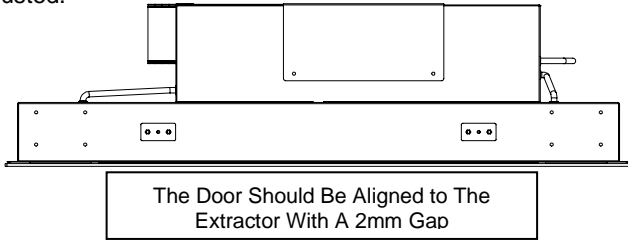

Should the door require adjustment left-to-right: back off the hinge fixing screws (one side at a time) to loosen the hinge from the base plate. This will allow the glass door to tilt to the required position. Once in place, re-tighten the hinge fixing screws.

NOTE: PROCEED WITH CAUTION. Only loosen the screws enough to allow the hinge to slide up and down with some resistance. Fully removing all 4 screws will detach the spreader plate mounted on the outboard side of the base plate. Should the spreader plate detach, the extractor will need to be lowered in order to re-attached the spreader plate.

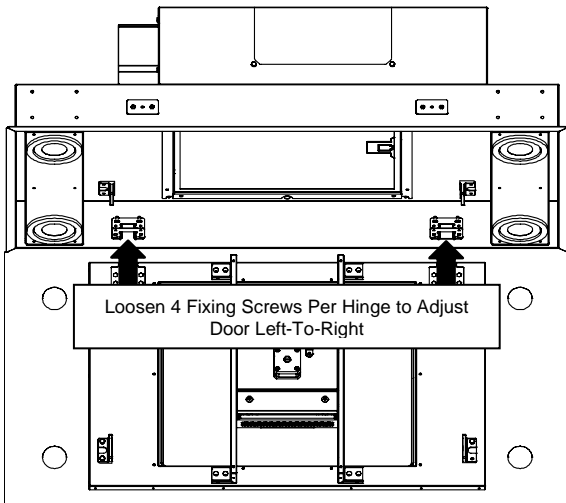

Should the glass door need to be adjusted front-to-back: there are two magnetic strikers mounted to the base plate which keeps the door aligned and keeps the door in the UP position.

Should the position of the magnets (and therefore the UP position of the door) be required to be adjusted, loosen the two fixing screws which retain the magnet against the base plate (one side at a time). Re-position the magnet to the required location, then re-tighten the fixing screws.

NOTE: Occasionally, the glass panel may become misaligned with the lights, this is due to the hinges and strut mechanisms pulling the glass panel up over time. Simply move the glass panel back into place by pushing on the opposing side of the glass panel to re-align with the lights.

NOTE: PROCEED WITH CAUTION. Only loosen the screws enough to allow the magnet to slide up and down with some resistance. Fully removing the two screws will detach the spreader plate mounted on the outboard side of the base plate. Should the spreader plate detach, the extractor will need to be lowered in order to re-attached the spreader plate.

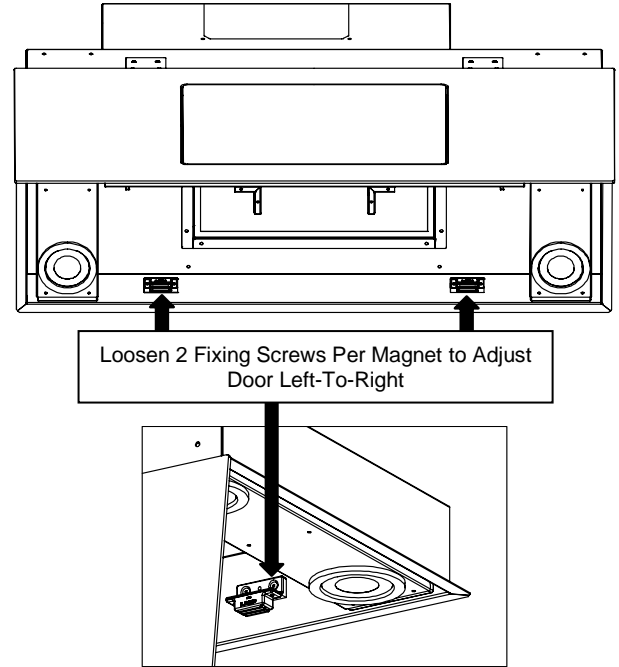

5. SPECIFICATIONS

All Models	
Supply voltage:	230V~ 50Hz
LED lamp voltage	12v
LED lamp power	4 x 3.4w
Recommended fuse size for electrical supply:	5A
Extractor Duct spigot size:	220mm x 90mm
Internal Motor Specification	
Motor airflow in free air:	805 m ³ /hr
Blower power input:	168W
Total power:	207W

W S Westin Ltd
 Phoenix Mills, Leeds Road, Huddersfield, HD1 6NG, UK
 Tel: 01484 421585
 Fax: 01484 432420
 Email: sales@westin.co.uk

Installation, Operating & Maintenance Instructions

6. OPERATING INSTRUCTIONS

Note: The unit is operated by radio remote control. In order to pair the remote control to the appliance:

- Switch on the power at the fused spur.
- Then Immediately turn on the remote control (⏻).
- Then immediately press and hold () until the lights illuminate.

Should the extractor fail to respond to commands from the remote-control, please check that the power is 'on' and the internal appliance reset switch is in the 'ON' position (factory default). The reset switch is a latching red push-switch located in the chamber behind the glass door panel.

If you experience interference problems, or the remote appears to be faulty from new, then a different radio transmission code may be required.

Refer to the instruction leaflet included with the remote control regarding transmission code changes before seeking assistance.

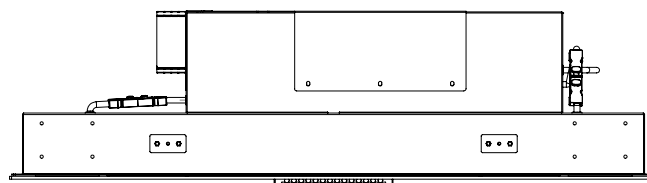

- The moving mechanisms within the appliance does not contain any user serviceable parts.
- Keep away from any moving parts.
- Accessing the moving mechanism for any reason will void the product warranty.

Abnormal Operations

Power Cut: Should the appliance lose power during operation; the central panel will remain in the open position until the power is reset at the fused spur or the reset switch. Once the power has been restored, the central panel will automatically retract. Normal operation can then be resumed.

Obstruction during central panel decent: Should the central panel become impeded during the downward cycle; the appliance will instruct the central panel to retract to the fully UP position. The central panel will then lower for a second attempt. If the panel is allowed to complete the downward operation unobstructed, the fan will start and normal operation can then be resumed. Should an impingement be detected for a second time, the central panel will retract and park in the fully UP position.

Obstruction during central panel retraction: Should the central panel become impeded during the upward cycle; the appliance will instruct the central panel to lower to the fully DOWN position. The central panel will then retract for a second attempt. If the panel is allowed to complete the upward operation unobstructed, the central panel will park UP and normal operation can then be resumed. Should an impingement be detected for a second time, the central panel will lower and park in the fully DOWN position. Note: the fan will still work with the central panel in the DOWN position.

System reset after impingement detection: Should the appliance detect an obstruction during the movement cycle of the central panel, then the panel will default to the parked position after two attempts to complete the cycle.

The appliance should be checked for obvious signs of obstruction only. If the obstruction can be easily removed, then do so. If the obstruction is undetectable, or if the obstruction is within the moving mechanism, then the appliance must not be disassembled to remove the obstruction. In this instance, please isolate the appliance and call Westin for assistance.

Should an obvious obstruction be removed from the appliance, the system can be reset at the fused spur (OFF then ON) or via the reset switch. Normal operation can then be resumed.

Remote Control Functions

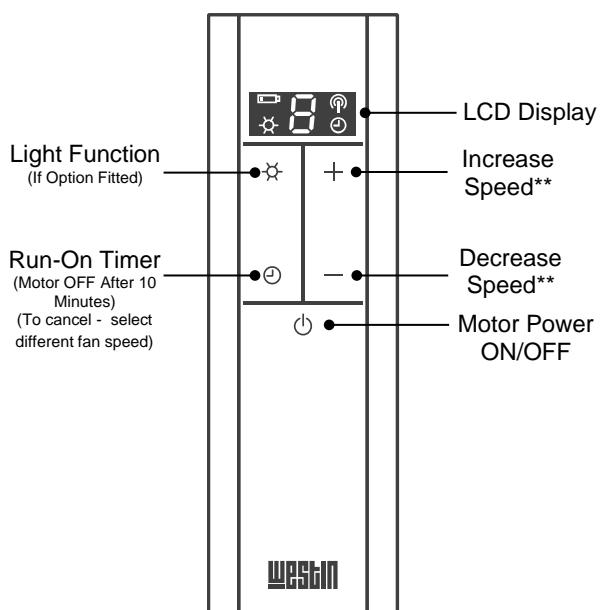

** The automatic speed reduction feature is required by EU Ecodesign and Energy Labelling Commission Legislation 65/2015 66/2014 in order to satisfy Directive 2009/125 EC*

Device operation

Turn ON the device by pressing (⏻).

The fan speed can be adjusted using (+) (-) on the remote control.

The central panel will gradually lower. Once in position, the fan will start.

Turn OFF the device by pressing (⏻) or (-) until the fan speed reads 0.

Note: The fan can only be turned off when the fan speed setting is on or above SPEED 2.

The appliance will turn OFF and the central panel will retract after 4 hours of continuous use.



Installation, Operating & Maintenance Instructions

7. MAINTENANCE

Regular maintenance is essential to ensure good performance and long-life.

CAUTION

To minimise the risk of fire, all instructions relating to cleaning the grease filters and removing grease deposits must be adhered to.

To maintain the immaculate appearance of the extractor and to minimise fire risk, ensure that grease deposits on the extractor surfaces are kept to a minimum by regular cleaning.

To clean the stainless-steel surfaces of the extractor, use a soft cloth and a suitable cleaning agent, such as a specially produced stainless-steel cleaner, or washing up detergent and warm water.

Painted surfaces should be cleaned using a soft cloth, detergent and warm water.

Glass surfaces should be cleaned with a suitable glass cleaning agent.

Do not use abrasive cleaning materials or products.

Do not use bleach-based cleaning materials or products.

Clean the grease filters in a dishwasher or by hand-washing in hot water and detergent every 2 months - sooner if the extractor is used extensively and filters become grease laden.

Whilst you can expect years of service from mesh grease filters, they are considered a consumable item and may deteriorate over time and need replacement, particularly when cleaned in a dishwasher. For dishwasher users adhering to a 2 monthly cleaning interval, we recommend grease filter replacement every 5 years to maintain optimum performance, even if they show no visible signs of deterioration. For all users, filters should be replaced whenever they exhibit signs of physical wear.

Accessing the filter(s) and baseplate

The panel is held shut with magnetic catches.

Open the panel by grasping it close to the corners on the catch side (usually the long edge opposite the hinges) and pulling to release the panel from the magnets. Take care not to let the panel fall open freely, it should be supported and lowered carefully into the open position.

Caring for HP4 high efficiency carbon filters (Recirculating hoods only).

To restore and regenerate high efficiency HP4 carbon filters, they must be washed in the dishwasher (without other dishes or cookware) and then be placed into an oven for 1 hour at max 90°C.

HP4 filters should be washed whenever they are dirty or lose effectiveness (at least every two months).

Regular washing and regeneration will maximise the efficiency and lifespan of these filters.

These filters can be regenerated repeatedly but are considered a consumable and will eventually deteriorate, after which they should be replaced. The time this takes will depend on the style of cooking but they can be expected to deliver excellent service under normal use conditions, although replacement is recommended at least every two years.

Replacing the LED Lamps.

LED lamp replacement needs to be done by Westin's After Sales Team, so please contact us for further information

WARNING

WHEN FILTER IS REMOVED, KEEP FINGERS AWAY FROM MOVING FAN PARTS.

SERIOUS INJURY MAY BE CAUSED IF THE FAN OUTER GUARD IS REMOVED.

DO NOT REMOVE OUTER FAN GUARD



Stratus MONO Ceiling Built-in Unit

Installation, Operating & Maintenance Instructions



900mm Version

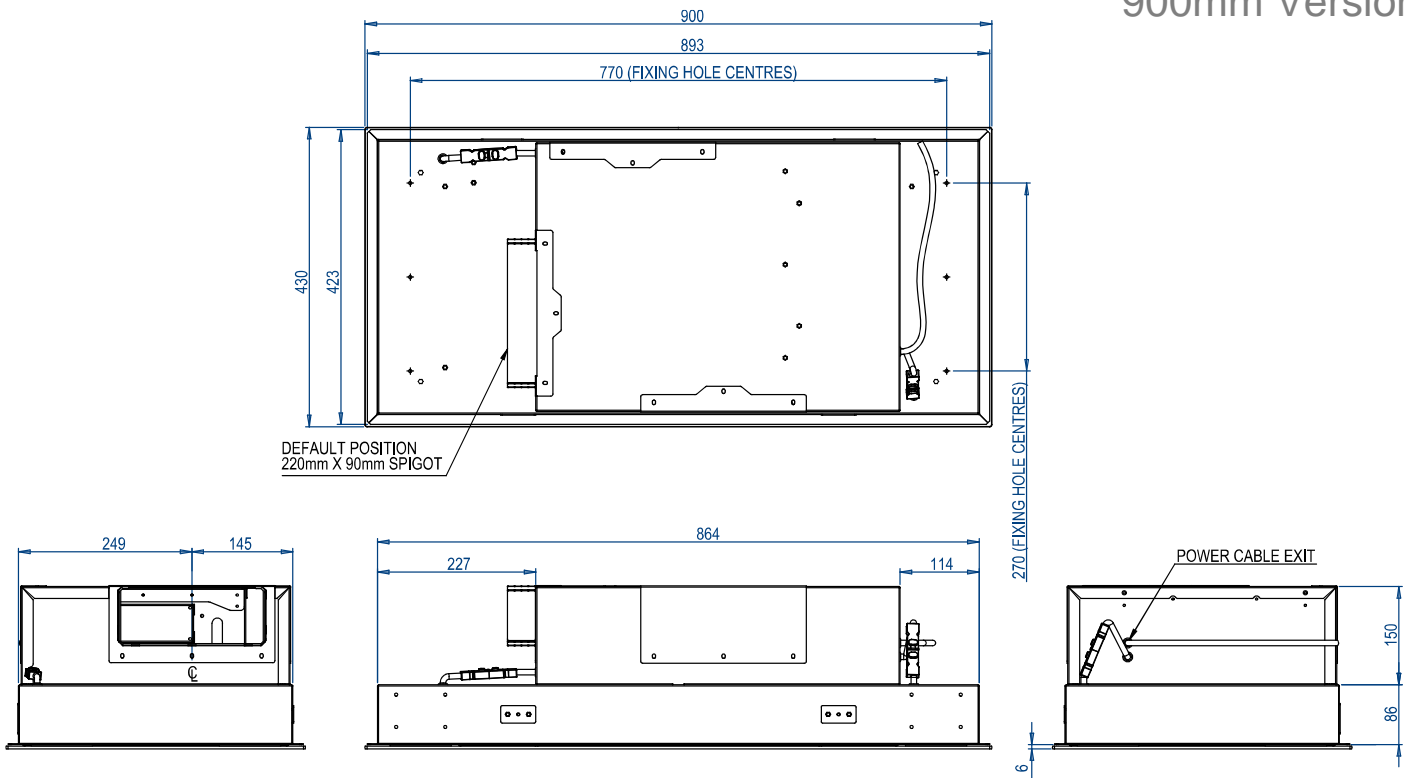

STRATUS MONO – OVERALL SIZES – INTERNAL MOTOR VERSION

Stratus MONO Ceiling Built-in Unit

Installation, Operating & Maintenance Instructions

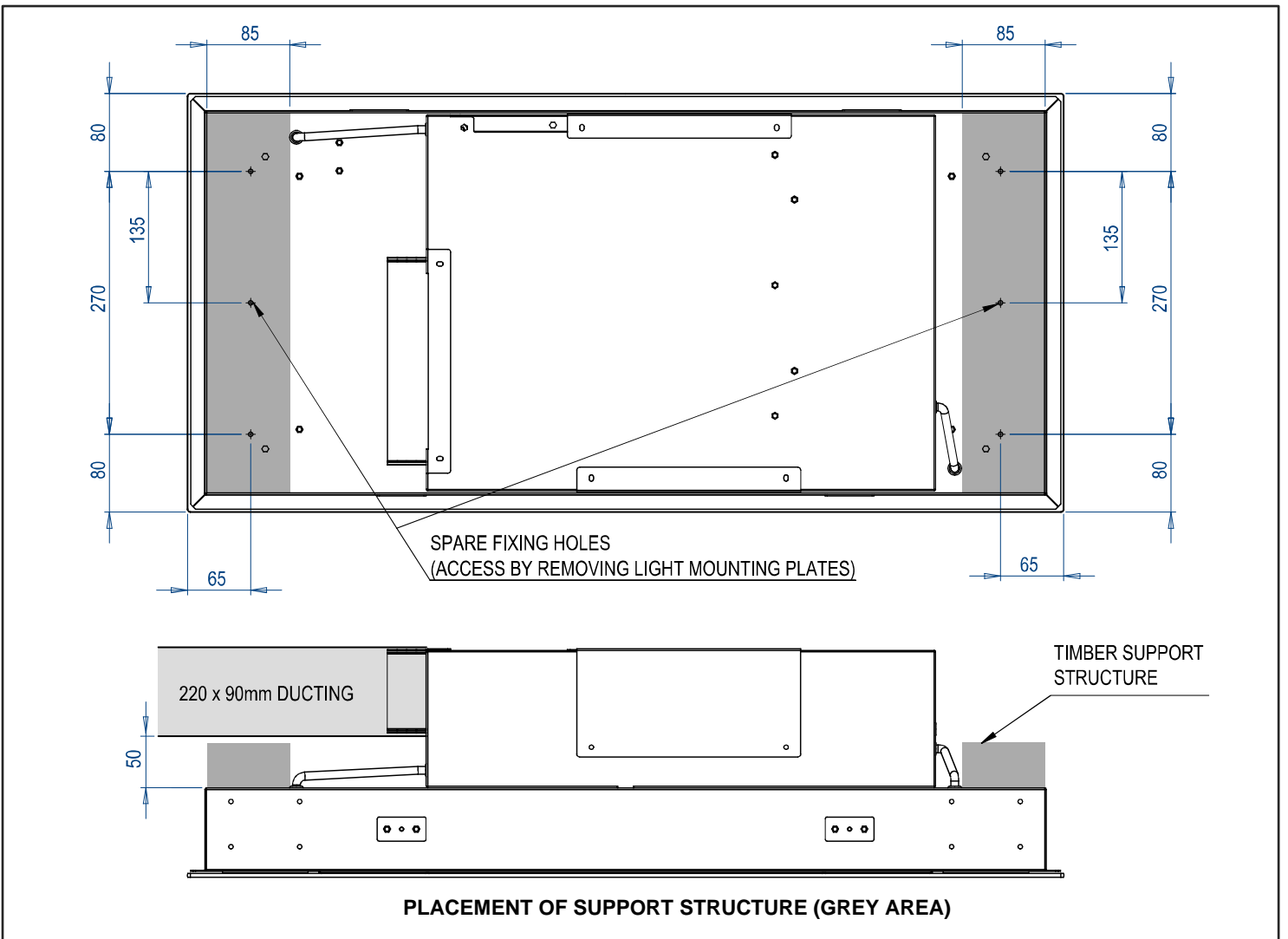
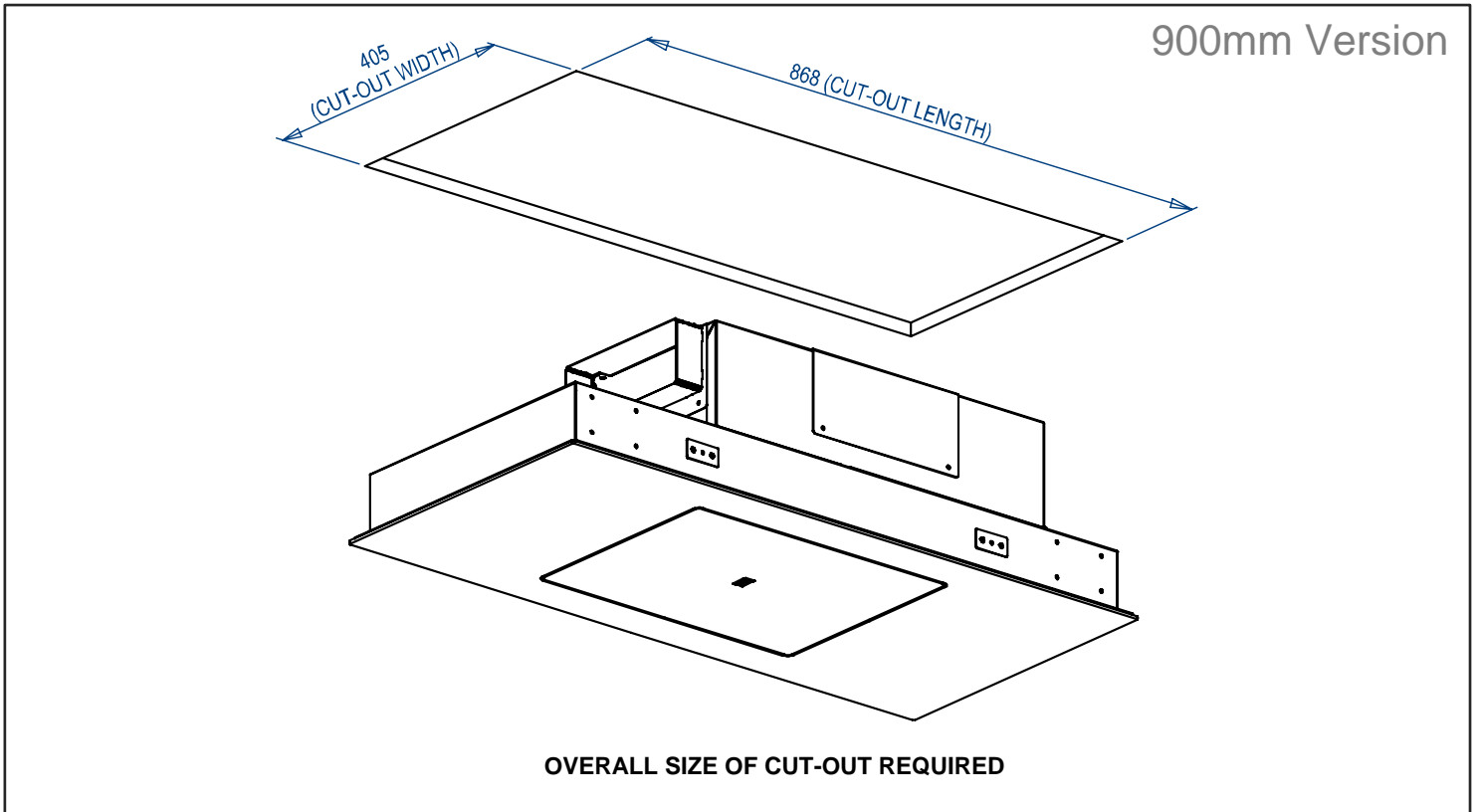

Stratus MONO Ceiling Built-in Unit

Installation, Operating & Maintenance Instructions



1200mm Version

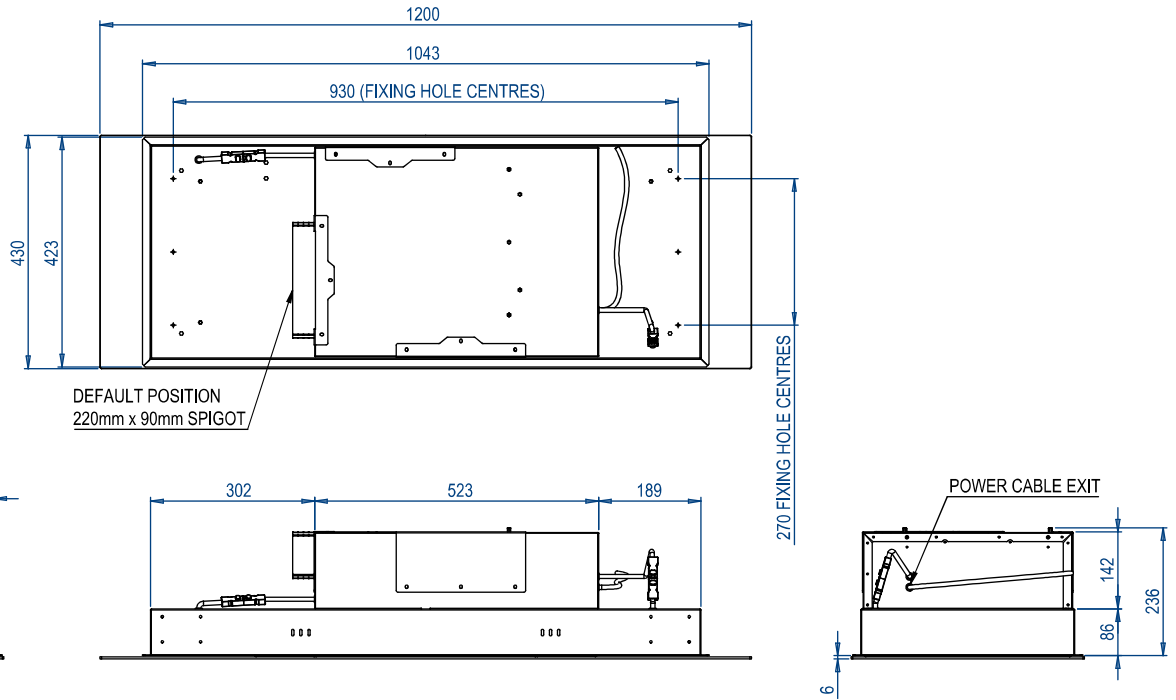

STRATUS MONO – OVERALL SIZES – INTERNAL MOTOR VERSION

Stratus MONO Ceiling Built-in Unit

Installation, Operating & Maintenance Instructions

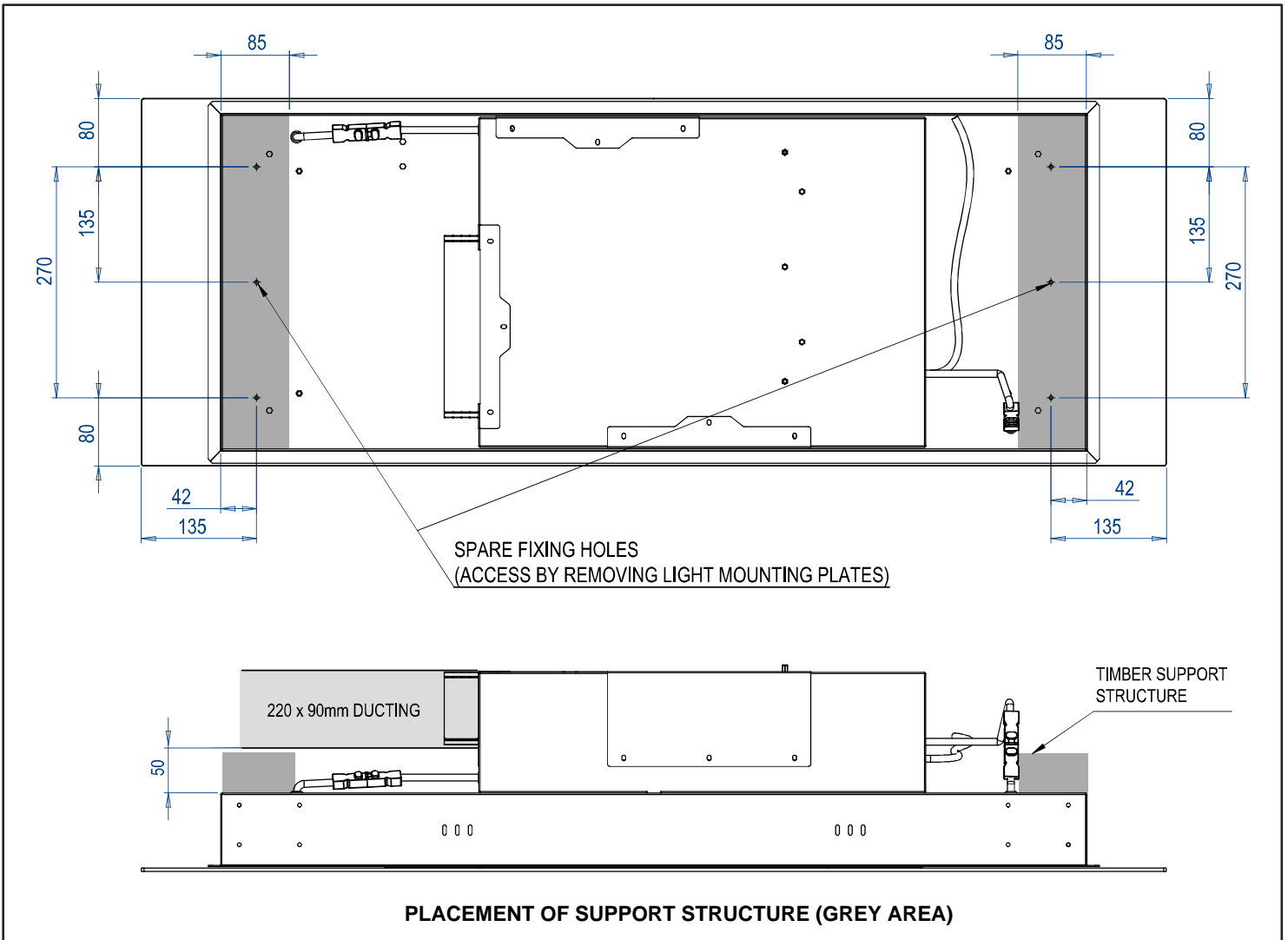
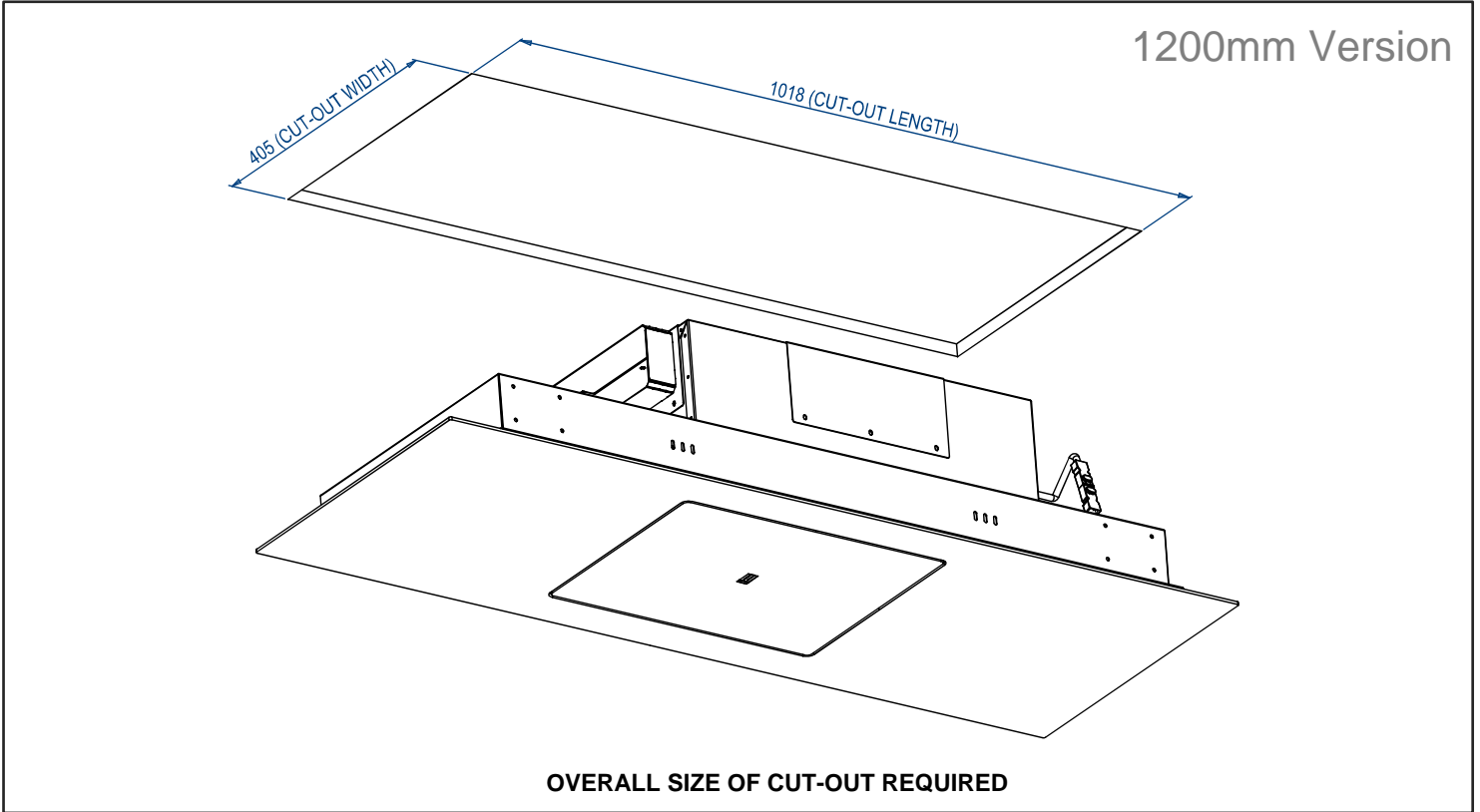

Motor	1 x Internal Motor
Lighting	4 x Dimmable LED Spot lights
Motor & Light Control	Radio Remote Control
Duct	1 x 220mm x 90mm Duct
Duct Position	Left, Right, Front or Rear (Please Specify when Ordering)
Soffit Opening (Cutout)	868mm x 405mm
Soffit Thickness	Minimum 15mm up to Maximum 22mm
Extractor Fixings	Extractor is fixed in place by 4 x fixing holes positioned behind the lights. An additional fixing hole is located behind each lighting panel if required.

REVISIONS				
ZONE	REV.	DESCRIPTION	DATE	APPROVED
	A	INITIAL RELEASE	08/10/2020	

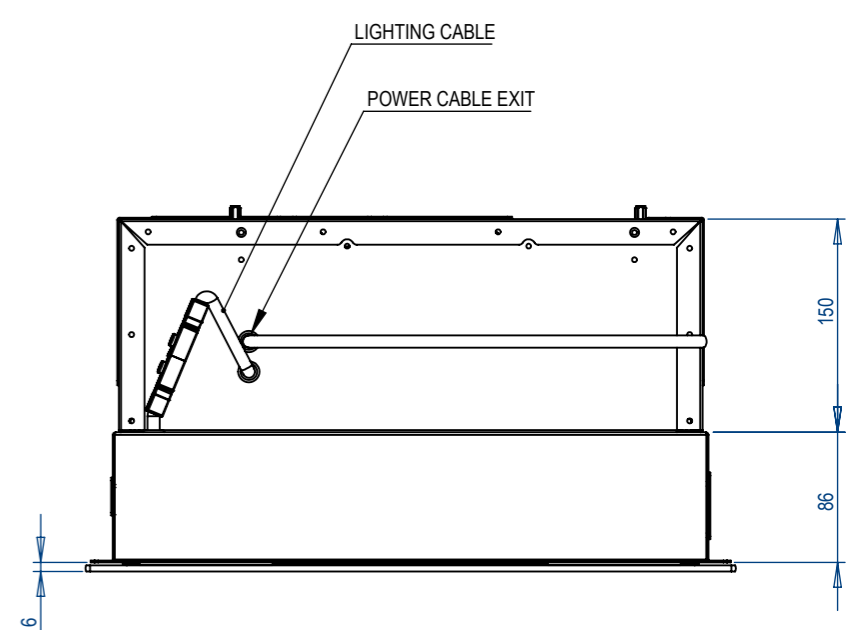
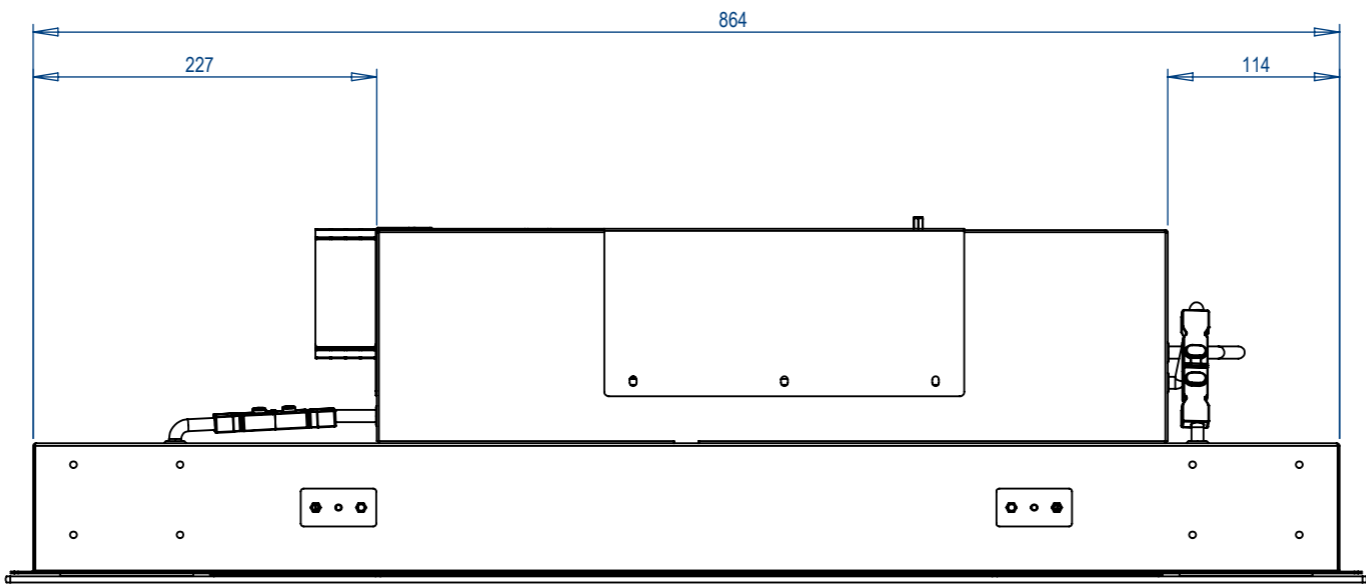
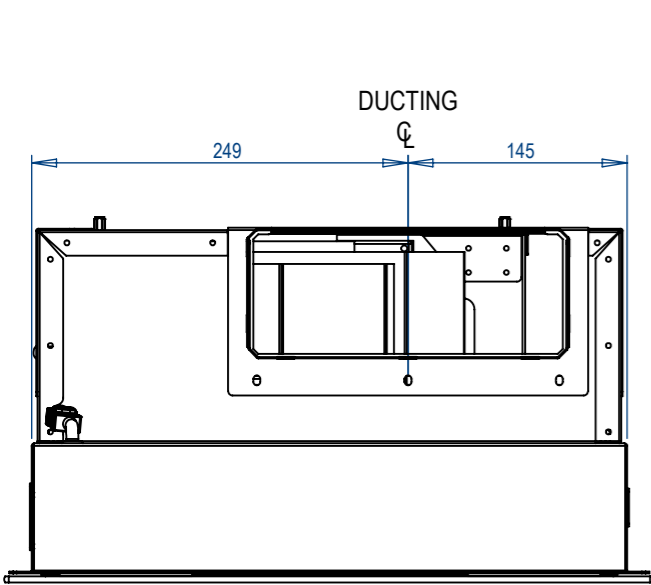
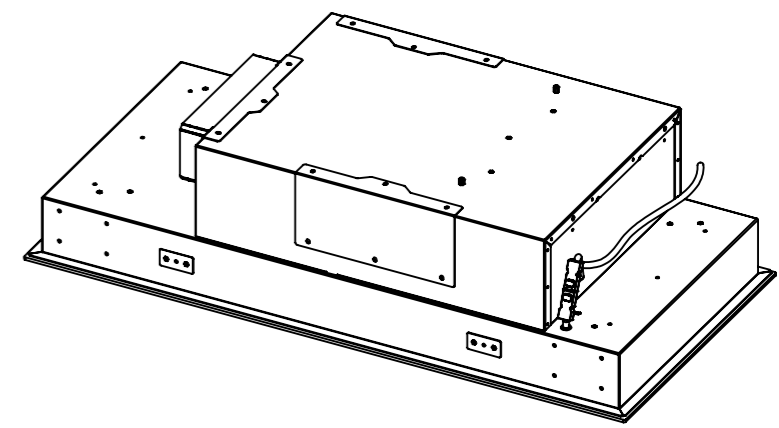
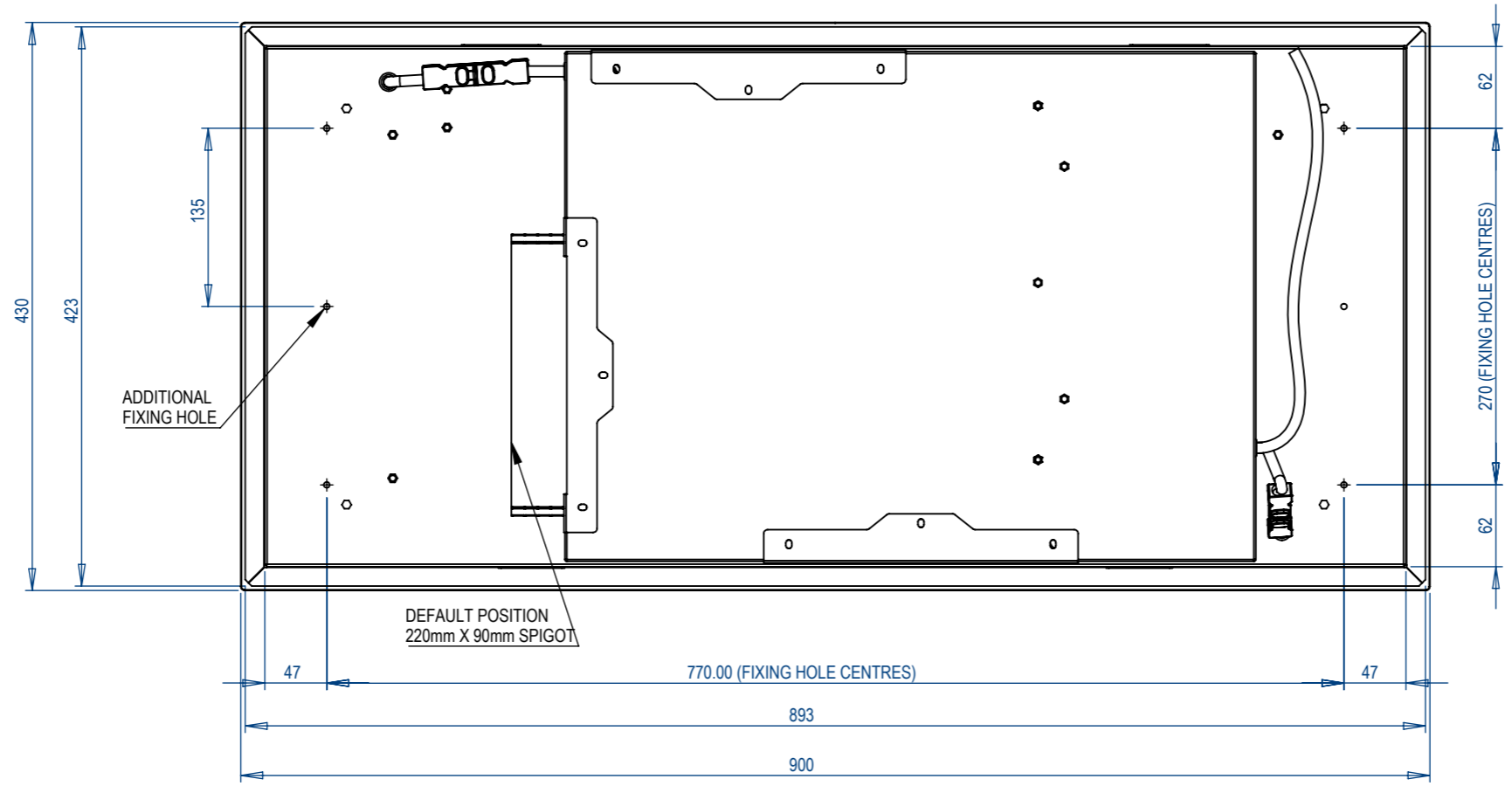

CLIENT. WS Westin Ltd
 DRAWN BY. M.BARNES
 TITLE. WSW Mono 900 GA V1 20201008

REFERENCE. REFERENCE
 APPROVED BY. MPB
 DATE APPROVED. 22/05/19

DO NOT SCALE DRAWING
 ALL DIMENSIONS ARE IN MILLIMETERS
 DRAWING MUST NOT BE RE-CIRCULATED WITHOUT THE PERMISSION OF WS WESTIN LTD

SCALE. DNS
 DWG NO.
 DATE. 08/10/2020
 A3/A4

Motor	1 x Internal Motor
Lighting	4 x Dimmable LED Spot lights
Motor & Light Control	Radio Remote Control
Duct	1 x 220mm x 90mm Duct
Duct Position	Left, Right, Front or Rear (Please Specify when Ordering)
Soffit Opening (Cutout)	1018mm x 405mm
Soffit Thickness	Minimum 15mm up to Maximum 22mm
Extractor Fixings	Extractor is fixed in place by 4 x fixing holes positioned behind the lights. An additional fixing hole is located behind each lighting panel if required.

REVISIONS				
ZONE	REV.	DESCRIPTION	DATE	APPROVED
	A	INITIAL RELEASE	09/10/2020	MPB

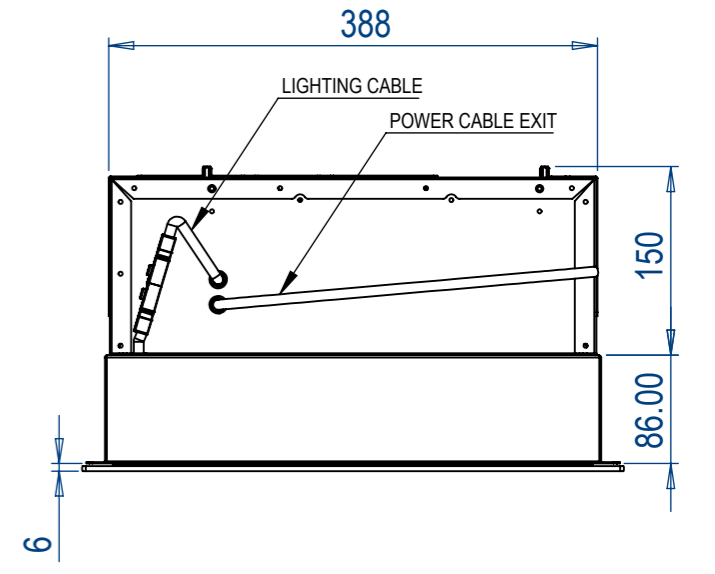
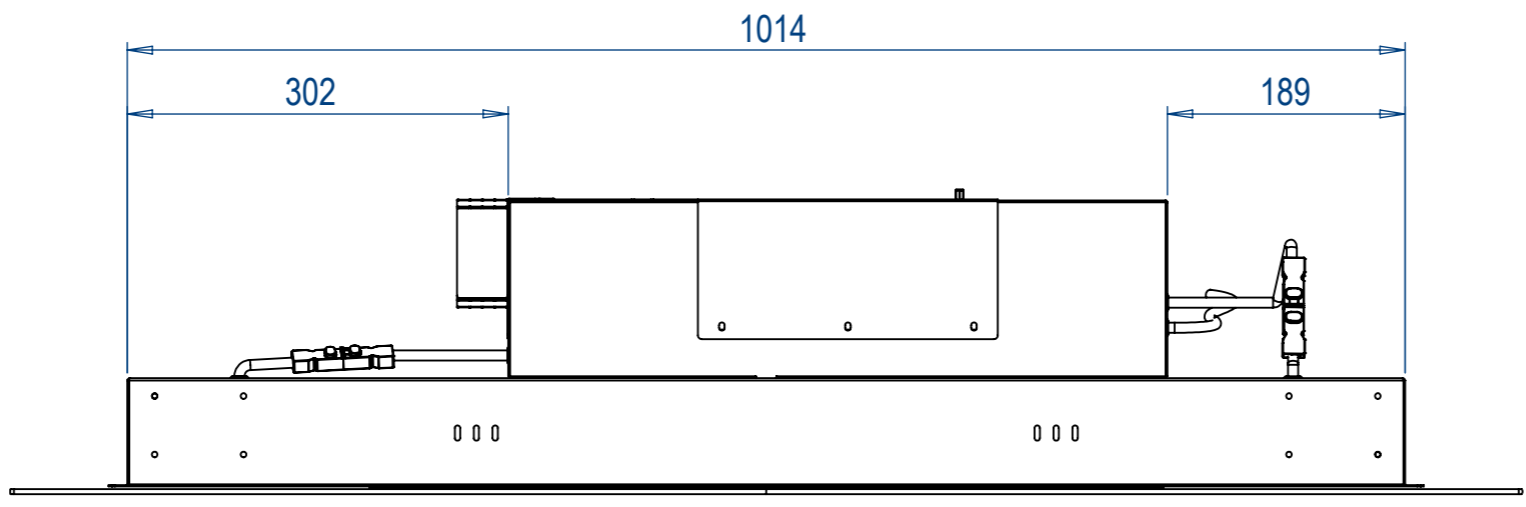
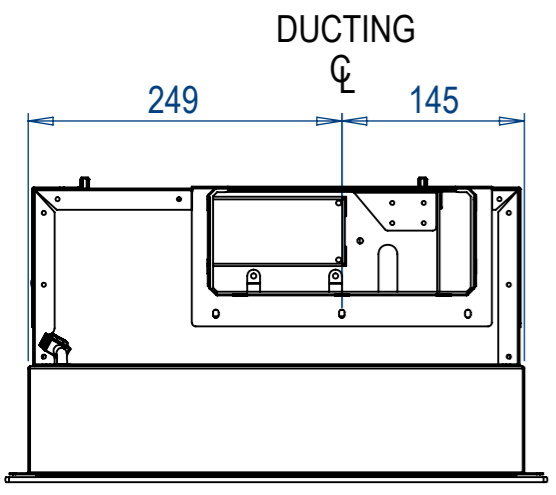
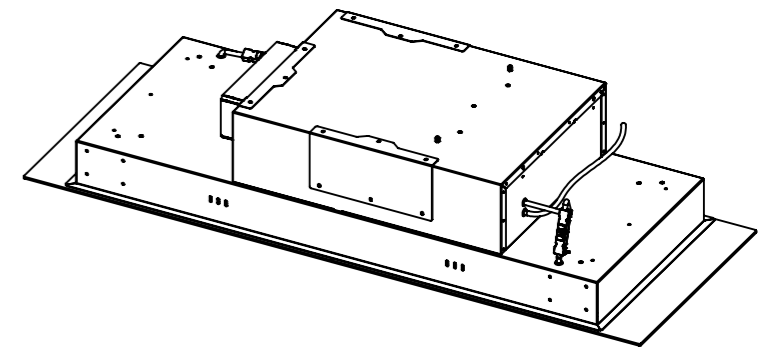
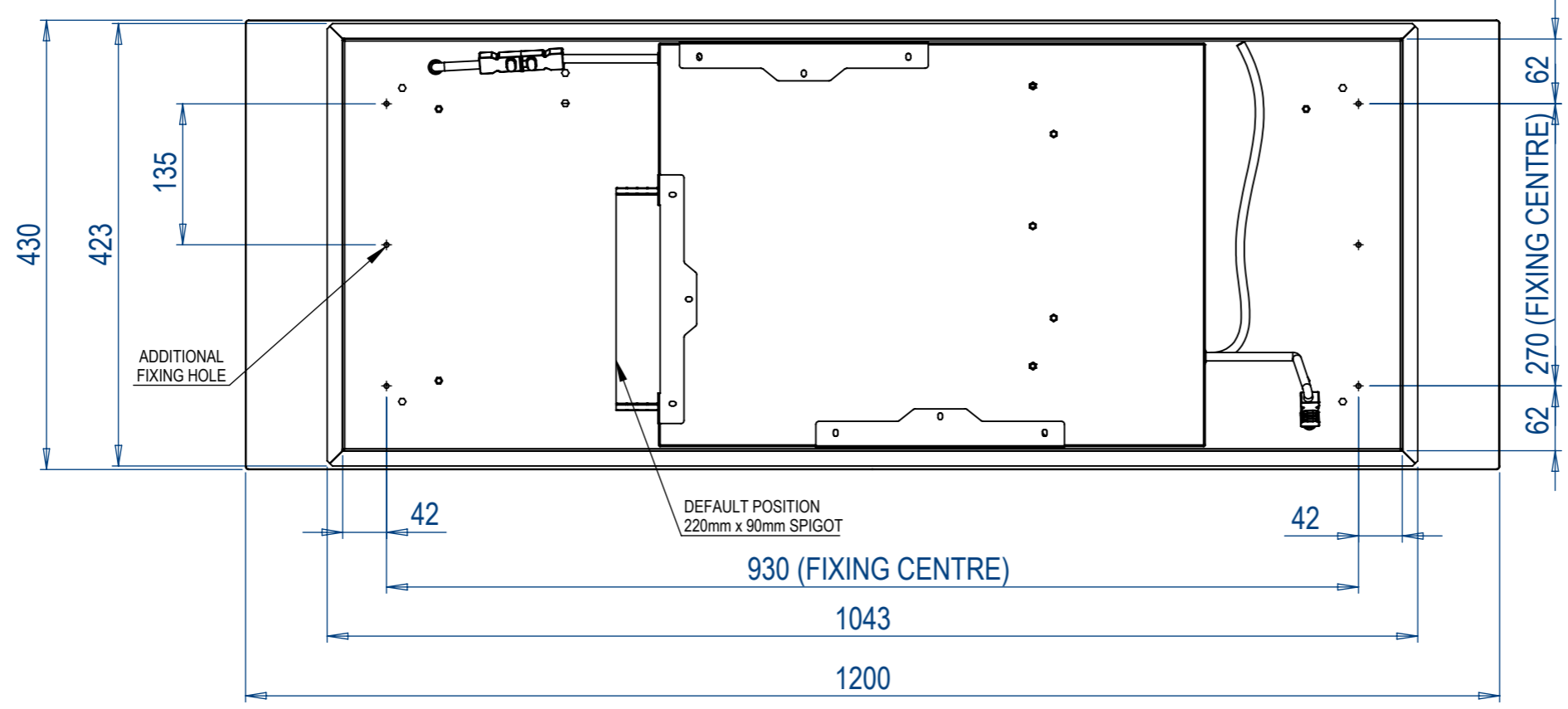

CLIENT. WS WESTIN LTD
 DRAWN BY. M.BARNES
 TITLE. WSW Mono 1200 GA V1 20201008

REFERENCE. REFERENCE
 APPROVED BY. MPB
 DATE APPROVED. DD/MM/YY

DO NOT SCALE DRAWING
 ALL DIMENSIONS ARE IN MILLIMETERS
 DRAWING MUST NOT BE RE-CIRCULATED WITHOUT THE PERMISSION OF WS WESTIN LTD

SCALE. DNS
 DWG NO.
 DATE. 09/10/2020
 A3/A4